



Company profile and reference projects of PROSE Ltd.

Presentation for

ABB

PROSE Ltd
Zuercherstrasse 41
8400 Winterthur
Switzerland

+41 52 262 74 00
Info@prose.ch
www.prose.ch

Profile of PROSE Ltd.

PROSE offers engineering and testing services for the railway focussed on rolling stock



All shares of PROSE Ltd. are owned by the management team of PROSE

History of PROSE Ltd.

- 1982 founded as Engineering Company, since 2000 focussed on Rolling Stock exclusively
- 2001: Integration of the testing laboratory of Bombardier Transportation (Switzerland), the former laboratory of SLM Swiss Locomotive and Machine Works Ltd.
- 2006: Foundation of the Notified Body SCORAIL
- 2009: Foundation of PROSE GmbH in Berlin, focussed on measuring wheelset technology
- 2011: Foundation of PROSE München GmbH
Competence in car body design and engineering

Structure of PROSE Ltd.

Staffing levels: 70 employees (60 engineers)
in Switzerland and Germany

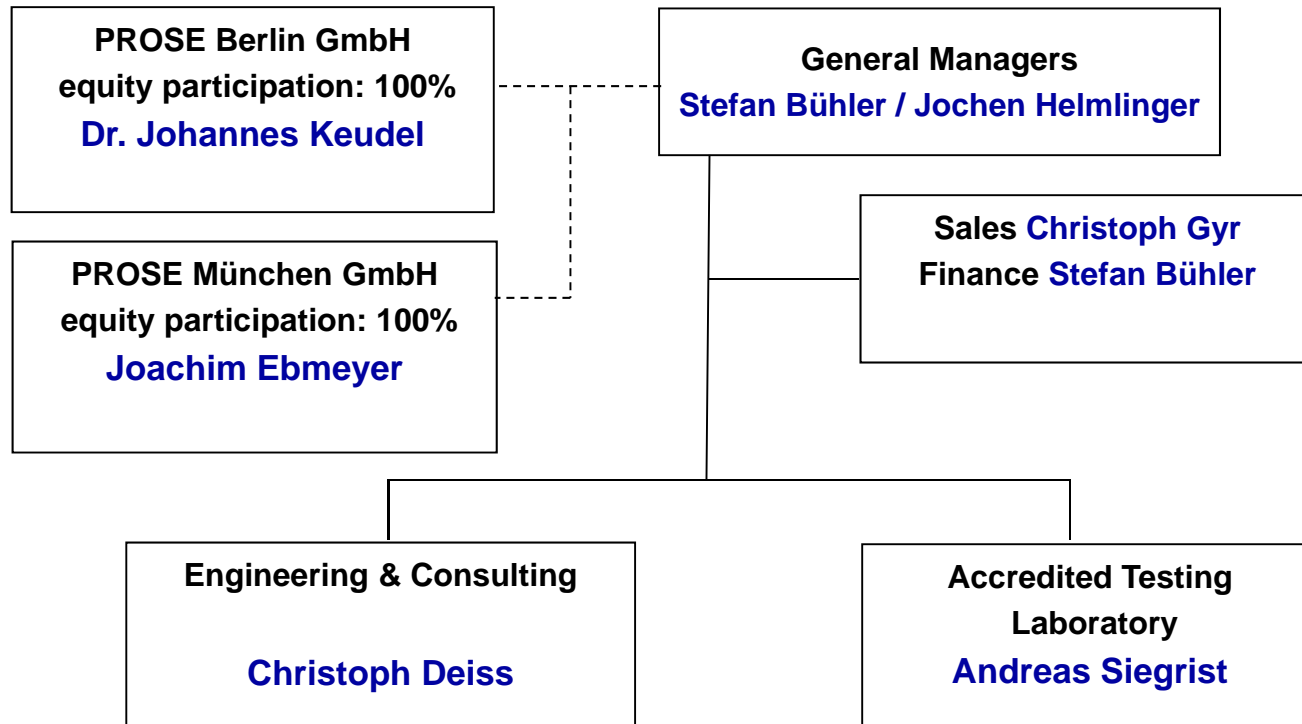

Stakes in: SCONRAIL AG an European certification body (33%)
Swiss Rail Traffic AG a private railway operator (20%)

Focus on Accredited Testing Laboratory



- Measurements for the approval process
 - Running dynamics
 - Brake system tests and measurements
 - Noise measurements
 - Service load spectra, determination by measurements
 - Interference currents
- Investigative measurements
 - for the improvement of vehicles,
 - for the elimination of problems,
 - or to support research processes
- Management of the approval process

Focus on Engineering & Simulation

- Development of complete rail vehicles placing emphasis on bogies and carbodies (body structure and vehicle's interior)
- Subsystem engineering and development
- Monitoring and control of the assembly process
- Placing into service operation, implementation of maintenance schemes and quality assurance processes
- Project management, interface management, coaching of development teams
- Stress analysis (e.g. employing FEM), Crash analyses
- Running dynamics analyses
- LCC/RAMS considerations, value analyses
- Design validation, inspections, design assessment and preparation of expert reports
- Fire protection, noise design, wheel profile design, ...

Focus on Noise & Vibration Control

- Noise reduction design for new and refurbished rolling stock (conception and engineering)
- Prediction of noise emission of new vehicles
- Noise reduction at the track (rail absorber, grinding, rail pads, sleepers)
- Environmental studies and elaboration of proposals for locations affected by railway noise
- Measuring and evaluation of immissions on living- and working-areas (noise and vibration)
- Monitoring of noise emission development (wheel and rail roughness)
- Measures to reduce railway vibrations into ground and buildings

Focus on Management Support & Consulting

- Preparation of technical specifications, evaluation of offers for railway rolling stock
- Support for the procurement process
- Maintenance of rolling stock
- Strategical and organisational consulting incl. implementation
- Efficiency improvement incl. innovation and cost reduction
- Optimisation of project management processes
- Driving the change process
- Evaluation and implementation of changes
- Time-based external interim project management

SCONRAIL Ltd.





Ihr Ticket für die Schienen der Welt

SCONRAIL ist die Zertifizierungsstelle und Benannte Stelle Interoperabilität der Eisenbahn in der Schweiz

- EG Zertifizierung von Sub-Systemen und Komponenten
- Begutachtung bezüglich Konformität mit den TSI
- Unabhängige Sicherheitsbegutachtung (ISA)
- Inspektion von Komponenten und Sub-Systemen
- Zertifizierung von ECM und Werkstätten

Für SCONRAIL stehen die technischen Experten der Trägerfirmen zur Verfügung

Ein Gemeinschaftsunternehmen von:   

SCONRAIL Ltd.



Home

Neuigkeiten

Über uns

**Versuchs-/
Messfahrten**

Personen-
Sonderverkehr

Güter-/
Sonderverkehr

Überführung
Spezialfahrzeuge

Serviceleistungen

Versuchs- und Messfahrten



Quality of PROSE Ltd.

Quality is an integral part of our work. We live a certified quality management system based on ISO 9001:2008

PROSE is certified as a design entity for welding on railway vehicles and components

SCHWEIZERISCHER VEREIN FÜR SCHWEISSTECHNIK
ASSOCIATION SUISSE POUR LA TECHNIQUE DU SOUDAGE
ASSOCIAZIONE SVIZZERA PER LA TECNICA DELLA SALDATURA



CERTIFICATE

Welding of railway vehicles and components according to EN 15085-2

This is to certify that: **PROSE AG**
Zürcherstr. 41

CH-8400 Winterthur

is qualified to perform welding work within the range of certification of

Certification level CL4 according to EN 15085-2



PROSE Ltd.
CH-8400 Winterthur

Certified area

Whole Company

Field of activity

Engineering, Consulting, Measuring, Testing and Test Equipment for Railway Rolling Stock

has implemented and maintains a **Management System**

which fulfills the requirements of the following standard:

ISO 9001:2008

Scope No.: 18_22_35
Issued on: 2008-07-09
Validity date: 2010-08-05
Registration Number: **CH-16093**



René Bärner
René Bärner
President of IQNet

Thomas Zolner
Thomas Zolner
Managing Director SQS



IQNet Partners*
AFNOR Spain APNOR Certification Bureau ABS Austria International Register AVET Austria APET B. Portugal CEMAR - UK/China
SABE China CQS Czech Republic CQC-Certification GmbH Germany IFC Denmark ISTAT France ICFR France
INSTITUTO BRASILEIRO DE CERTIFICACAO BRASILIA Group Korea KQNET SE, Finlande IFSIC Mexico IspaqnetCertificationPoland BLSM Argentina
IQA Japan KIQ Korea NEMT Hungary Tuvker SA Portugal TUV Nord Austria TUV SUD Austria TUV Rheinland TUV SUD Austria
SQS Services SQS International Malaysia SQS International UK, Germany TST B. Paraguay Brazil TSI, Turkey VQS Serbia
IQNet is represented in the IIR by: ABS Austria Certification, CEMAR, ICFR, ISTAT, Ispaqnet, KQNET and TUV SUD.

* The list of IQNet partners is available at the end of every certificate. Detailed information is available under www.certification.com

Quality of PROSE Ltd.



STS 409

PROSE is an accredited testing laboratory for railway rolling stock and Notified Body No. 1990 for machine noise

 Schweizerische Eidgenossenschaft
Confédération suisse
Confederazione Svizzera
Confederaziun svizra

 Eidgenössisches Departement für Umwelt, Verkehr, Energie und Kommunikation UVEK
Bundesamt für Umwelt BAFU

 Eidgenössische Kommission für die Anerkennung von Normen (EKON) / Swiss Accreditation Service (SAS)

Bezeichnungsurkunde

Gestützt auf Artikel 11 des Abkommens zwischen der der Schweizerischen Eidgenossenschaft und der Europäischen Gemeinschaft über die gegenseitige Anerkennung von Konformitätsbewertungen vom 21. Juni 1999 (MRA CH-EG, SR 0.946.526.81) und gestützt auf Artikel 31, der Verordnung über das schweizerische Akkreditierungssystem und die Bezeichnung von Prüf-, Konformitätsbewertungs-, und Zulassungsstellen vom 17. Juni 1996 (AKKBV, SR 946.512) wird die

PROSE AG
Zürcherstrasse 41
8400 Winterthur

mit der Akkreditierungsnummer STS 409 und Notified-Body-Nummer NB 1990 als

Prüfstelle

bezeichnet zur

Bestimmung von Schalleistungspegeln von Geräten und Maschinen, die im Freien verwendet werden.

Geltungsbereich und Geltungsdauer richten sich nach dem offiziellen Verzeichnis akkreditierter Zertifizierungsstellen, dem oben genannten Abkommen sowie der Bezeichnungsverfügung des BAFU vom 5. Februar 2008.

Bern, 5. Februar 2008
Bundesamt für Umwelt

Gérard Poffet
Vizedirektor



(Noted on the Akkreditation and Designation Ordinance dated 17 June 1996 (as of 1 December 2007) and on the advice of the Federal Accreditation Commission, the Swiss Accreditation Service (SAS) (AKKBV))

PROSE AG
Measuring & Testing, M & T
Zürcherstrasse 41
CH-8400 Winterthur

its accreditation as

Testing laboratory for Railway Rolling Stock and Machine Acoustics

in accordance with the Standard ISO/IEC 17025. The scope of accreditation is defined in the Official Directory of the Accredited Testing Laboratories.

Akkreditationsnummer und -nummer: STS 409
(Date of accreditation: 10 June 2004)
Date of the next renewal of accreditation: 10 June 2009
The accreditation is valid until: 9 June 2014.

CH-9000 Bern, Walden, 25. Juli 2008
Swiss Accreditation Service



The Head
Hanspeter Bach

SAS is a agency of the multiple members of the Swiss Confederation. Its mission is to bring inspection and certification of process, customer supply and environmental management systems. Other recognized accreditation bodies (ANB) for technical standards, quality and environmental management systems are in the Swiss Confederation. Laboratory Accreditation Cooperation (ILAC) for calibration and testing.



**Selected Reference
Projects
of
PROSE Ltd.**

Acceptance Tests

2010

Alstom ETR 245 für LeNORD (Italy)

...

Siemens Desiro Mainline (Belgium)
and others



Acceptance Tests

2010 Matisa Track renewal Train P95 for Eiffage (France)
... Freight Wagons



Acceptance Tests

2011 Vossloh – Loc family G18/DE18

(on behalf of Vossloh Locomotives)

- Complete tests of the running behaviour in Switzerland for an all-European acceptance
- Running characteristics according to EN 14363 with PROSE-measuring wheelset
- Method using different conicities for acceptance on rail inclinations of 1:20 und 1:40



Acceptance Tests

2012 **Stadler Bussnang AG – EMU FINK**
on behalf of Stadler Bussnang AG
(Final customer: Zentralbahn, Switzerland)

- Acceptance tests on entire metre-gauge network of Zentralbahn in Switzerland
- Running characteristics according to EN 14363 – simplified method
- Simultaneous measurements of load spectra on two motor bogies (rack-wheel and adhesion bogie) with strain gauges
- Combined measurement allowed for short test time



Acceptance Tests

2006 - today

Noise measurements according to
TSI CR NOISE for several customers

- Measurements executed with freight wagons, locomotives, multiple units, on-track maintenance machines
- Reference track section according to TSI NOISE available in Switzerland



Vehicle approval process management

2008 - 2009 Approval of low floor vehicle INOVA

(under contract of Bombardier, End customer Swiss Federal Railways)

- Performance of running dynamics type tests and braking distance measurements
- Measurements to determine the ride comfort index, push-pull tests while running through switchpoints and noise measurements
- On behalf of Swiss Federal Railways, obtaining approval of the vehicle by the Federal Office of Transport (Switzerland)



Acceptance Tests

2008 - 2009

**Push-Pull-Trains –
Overall project management**
(for Siemens; end customer: Israel Railways)

- Definition of the test requirements together with the manufacturer, the end customer and the responsible authority and preparation of the relevant specifications
- Performance of:
simplified running dynamic
type tests, brake system tests,
push-pull tests on switchpoints,
EMC-Testing as well as noise
measurements
- Organisation of the complete test
program including loading,
operation permits, traction, etc.



Acceptance Tests

1999 - 2005 **Norwegian State Railways NSB, Norway** (for Bombardier, Switzerland and AnsaldoBreda, Italy)

- Performance of the complete running dynamic type test, brake system type test and noise type test at the EMU NSB Class 72, designed and manufactured by AnsaldoBreda and Bombardier
- Service load collective determination including axle stress measurements
- Commissioning and management of services during warranty period



STS 409

Acceptance Tests

2001 - 2006 **Spanish State Railways (RENFE AVE), Spain** (for Bombardier and Talgo)

- Running dynamics and noise approval tests for the prototype of the high speed power head train set Talgo 350
- Approval test management, noise design, noise testing and measurement for the optimisation of the adhesion control of the high speed power head of the high speed train set AVE S102
- Accredited running dynamic test of the complete train set AVE S102 (coaches and power head)



Acceptance Tests

2004 Probotec SARL, Luxembourg

- Running dynamic measurements (with measuring wheel sets) for an approval in Germany according UIC 518 for a Tanoos-type wagon with AM III “Axle Motion” bogies of Probotec (today AXIOM Rail)



STS 409

Acceptance Tests

2001 LKAB, Sweden (for Bombardier)

- Brake system tests (static and dynamic)



STS 409

Research / Design Validation

2006 **Spanish State Railway (RENFE - AVE), Spain**
(for Siemens, Germany)

- Noise measurements during the development for validation and optimisation purposes of the AVE S103 train sets (Velaro E)



Design Validation

2001 - 2002 **New Jersey Transit Authority, U.S.A.** (for Bombardier)

- Determination of the mechanical load at bogie and drive system to optimise the traction control system for the prolongation of life time of the system of the ALP 46 locomotive of New Jersey Transit Authority performed at the American test center TTCI in Pueblo (Colorado)
- Similar Measurements at different locomotive types in Europe



Fully Automatic Measuring System

2008 Long-term investigation of VR Locomotive Sr2 (on behalf of VR Finland, Bombardier Transportation)

- Investigation of the running behaviour of two locomotives in regular service under harsh winter conditions
- Data recording triggered by events (speed etc.)
- On-line monitoring of measuring system and real time transmission of characteristic values
- Off-line data processing and plotting for the analysis of the comprehensive data
- Customised measuring system delivering accurate measuring data
- Installation of the measuring system by PROSE



Research / Validation

2006 LEILA project team, Switzerland

(for Josef Meyer Waggon, Rheinfelden, Switzerland)

- Validation of the LEILA running gears and performance of approval tests together with project partners in the field of running dynamics, braking system, service load collective and noise
- Test management and operations



Measuring Wheelsets

- Determination of the running safety
- Measuring wheel / rail forces with regard to
 - Stability
 - Track shifting force
 - Safety against derailment



Measuring Wheelsets

- Two measuring principles
 - „Combined Method“ in which the axle and the wheel are instrumented with strain gauges
 - Able to handle all drive types including quill drive
 - Applicable also on plain wheels
 - „Web-only-method“ in which all strain gauges are applied to the wheel
 - More precise than the combined method
 - S-shaped wheels required
- Measurements according to EN 14363 / UIC 518
- Measurements during push-pull tests while running through switchpoints

Measuring Wheelsets

- highly reliable
 - measuring wheelsets are investments and can be used over a long period of time
- standardised interfaces lead to reduced system costs
 - reusable telemetry systems
 - reusable measuring wheelset computer for the force calculation
- signal transmission via
 - slip ring
 - optical axially mounted telemetry
 - radio-based (digital)
- easy-to-use measuring wheelset computer
 - no special training needed
 - no need of support by PROSE

Roller Test Rig

**2010 - 2013 Chinese Academy of Rail Sciences
Roller Test Rig – CARS RTR**

Customer: RENK Test System, Augsburg

- Instrumentation of the track-wheel into a measuring wheelset
- Additional measuring wheelset for calibration of the track-wheel
- Design of the axle-mount (bogie-half-frame)

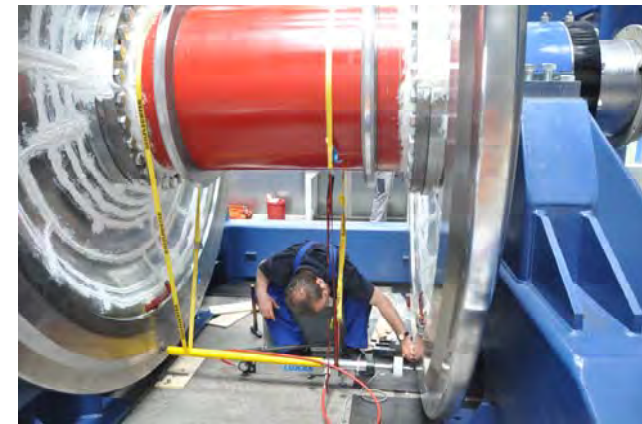

Resistance Measurement of a Wheel Set

2009 Resistance measurement of a wheel set on a SBB double-deck EMU

(on behalf of SBB, Stadler)

- Measurement of the electrical resistance of a wheel set according to EN 13260 und UIC 512



Conception, Evaluation, Engineering

1983 - 2009 Metro de Medellín, Colombia

- Evaluation of the offers from international consortia
 - Support at the contract negotiations
 - Design supervision, supervision of manufacturing and testing
 - Homologation of the rolling stock
- Support to the operator in regard to
 - wheel wear and noise
 - structural carbody problems



Conceptional Design, Evaluation, Surveillance

1997 - 2003 **Metro de Valencia, Venezuela**
Metro de Maracaibo, Venezuela
MRTA Bangkok

- Evaluation of the rolling stock and signalling system offers from international consortia
- Support at the contract negotiations
- Design assessment, supervision of manufacturing and testing of rolling stock and signalling system
- Homologation of the rolling stock and signalling system



Conceptional Design

1997 KH Mühlhäuser Tunnel Equipment, Michelstadt, Germany

- Conception of bogies for wagons for the transport of excavated material from tunnels (Axle load 15 t, disc brakes, progressive Suspension)
- Surveillance of the production and the commissioning of the wagons

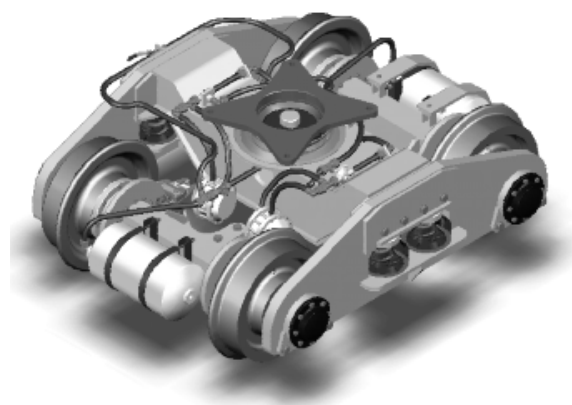

Development / Design / Vehicle

2011 - Wuppertal, Germany - Suspended Monorail

(for Vossloh Kiepe Düsseldorf, Germany)

PROSE is responsible for the entire mechanical development, consisting of the vehicle body, the vehicle interior and the running gear.



Development / Design / Bogie

2011 - Suspended monorail vehicles
Wuppertal, Germany

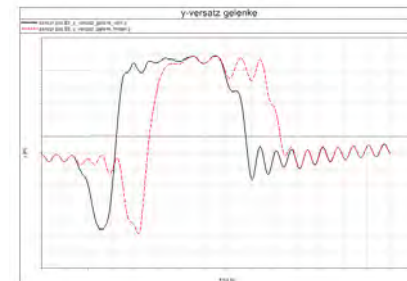
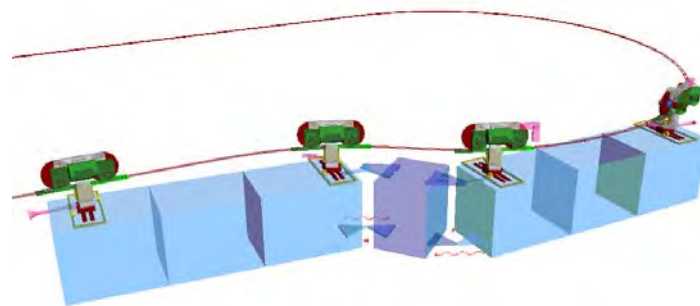
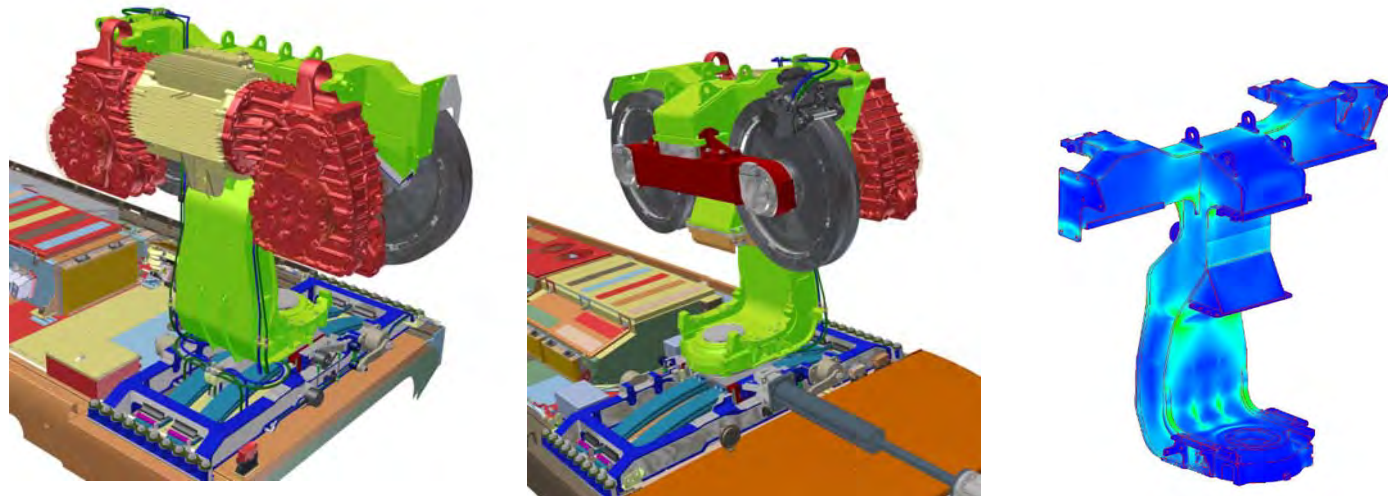

Development / Design

2011 - Suspended monorail vehicles
Wuppertal, Germany

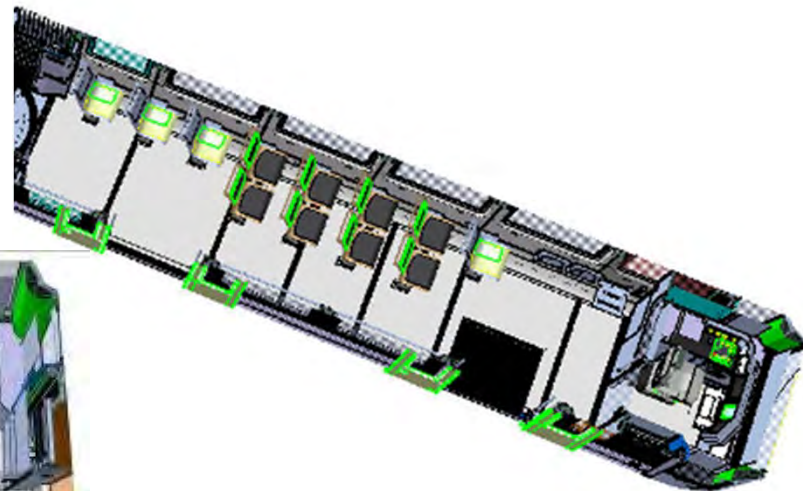
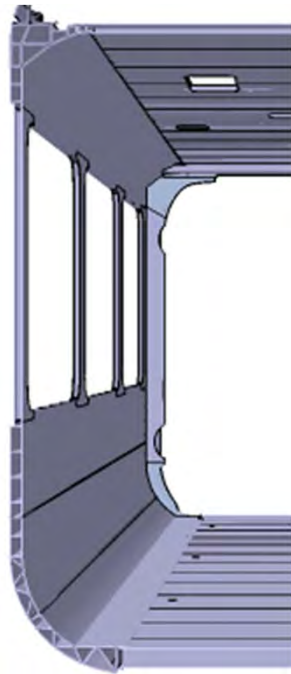

Development / Design

2010 - 2011 Cable car Penang Hill Malaysia New Coach 2

- Design of aluminum carbody relying on profiles already employed by the manufacturer
- Industrial design of the carbody structure
- Static and fatigue strength analysis considering specific loads for cable cars
- Proof report on carbody strength according to requirements of safety authority
- Coordination of interfaces carbody/running gears



Development / Design

2009 - 2011 **MANTENA AS - Installation of magnetic track brake on NSB EL 18 & NSB B7 Passanger Coaches**

- Feasibility study for the installation of an electromagnetic track brake at the electric locomotive EL 18 for the Norwegian state railway
- Final design of guiding supports and FE calculation of supports on bogie frame.
- Routing of additional piping and cabling
- Assistance for type tests in Norway



Development / Design / Bogie

2011 - 2012 **HKL, Helsinki City Transport Utility**
 (for Transtech Oy, Finland)

- Development of a low-floor motor bogie in narrow gauge for a low floor tram

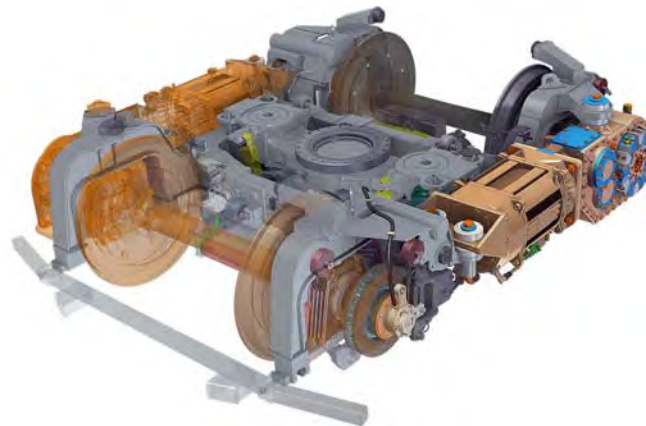

Main Data:

Bogie Data

Gauge: 1000 mm
 Wheelbase: 1700 mm
 Wheel diameter (new): 680 mm
 Weight of Bogie: 4.4 t

Height interface carbody: 5500mm

Vehicle Data

Tare Weight: 41.6 t
 Maximum Axle Load: 9 t
 Maximum Speed: 80 km/h

Power: 8 x 65 kW

Development / Design

2010 - 2011 Schalker Eisenhütte Maschinenfabrik GmbH

- Conception and development of the motor bogies for a diesel electric narrow gauge locomotive, including running dynamics
- Service operation planned on characteristic lines with numerous narrow curves in the Swiss Alps. Maximum speed 100 km/h
- At the moment 4 locomotives are ordered, mainly used for heavy track construction and maintenance purposes

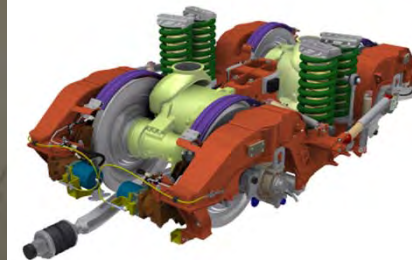
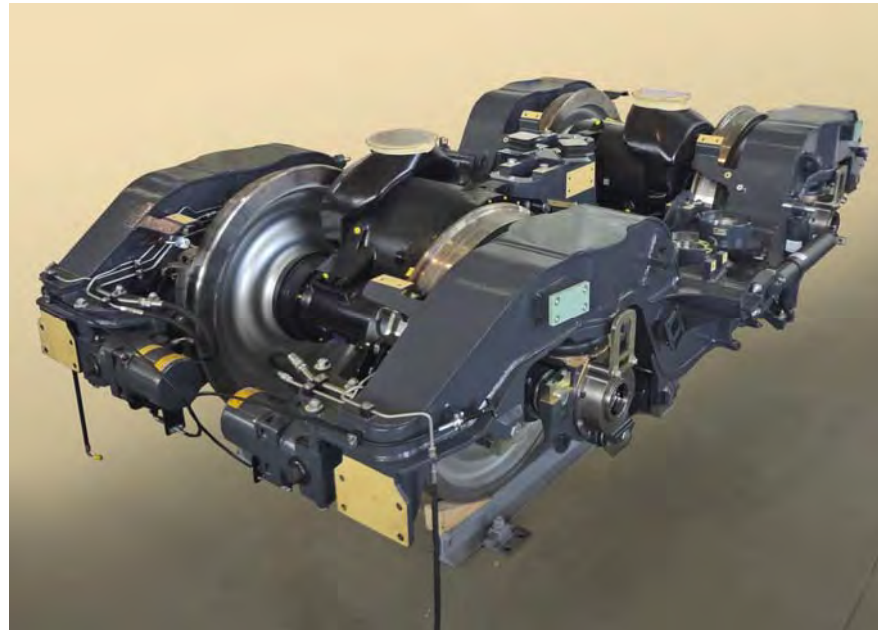

Development / Design

2009 - 2010 Running dynamics analysis and optimisation for a tram (standard gauge)

- Running dynamics simulation of the existing vehicle configuration on new network sections
- Evaluation of the overall concept and sensitivity analysis on component properties
- Proposal for an optimised secondary suspension and damping parameters

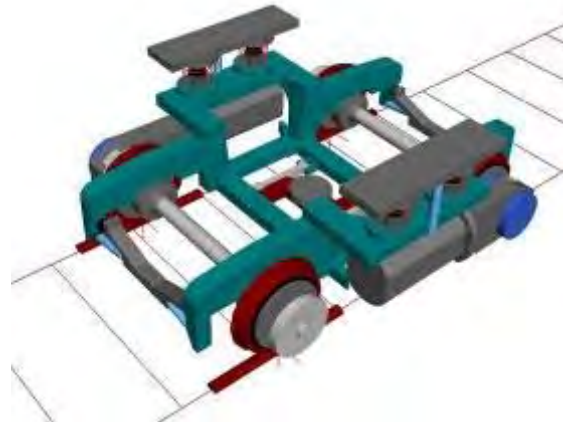

Development / Design

2008 - 2009 Bogies for heavy Co'Co' freight locomotive

- Development of bogies for a six axle freight locomotive
- Stress analysis
- Running dynamic analysis

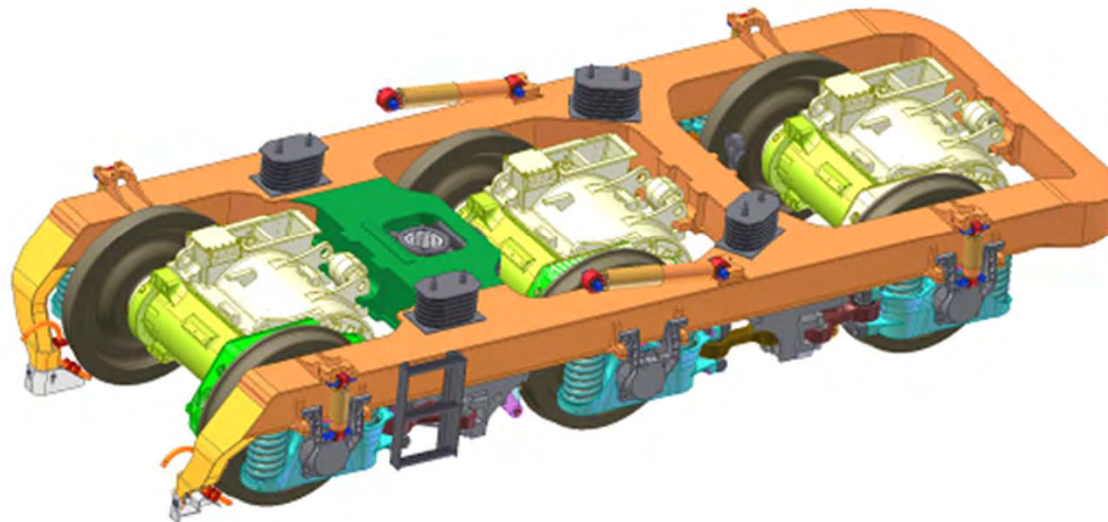

Engineering Assistance

**2009 CRH1-380 "Zefiro" –
Engineering Support for brake components**
(for KNORR, Munich Germany)

- Input and second opinion for the Claus to Clause comments of KNORR offer
- Technical Assessment of brake components to be offered
- Input regarding the load assumptions (vibration at high speed, etc.) for the design and validation of the brake components



Development / Design

2008 - 2009 MOB Gauge Changing Trailing Bogies

- Development and manufacturing design of a variable gauge bogie with loose wheels (Gauge: 1'000 mm and 1'435 mm)

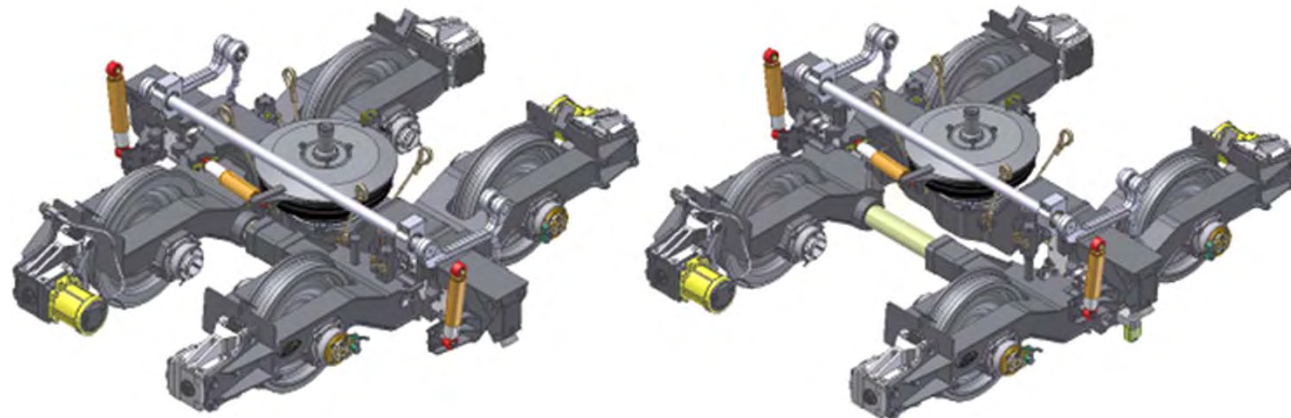

Development / Design

2005 - 2007 MTR Mass Transit Railway Corporation, Hong Kong

- Stress analysis and redesign of the antenna-support beam at the bogies of the EMUs of the Lantau Airport Railway and the Tung Chung Line
- Service load collective measurement, vibration testing and service testing
- Production of 48 antenna-beams



Development / Design

2006 - 2007 Queensland Rail, Australia (for Siemens, Graz)

- Conception and development of bogies for the electric Bo'Bo'Bo' locomotive to be used to haul heavy coal trains in Queensland on lines with 1'067 mm track gauge

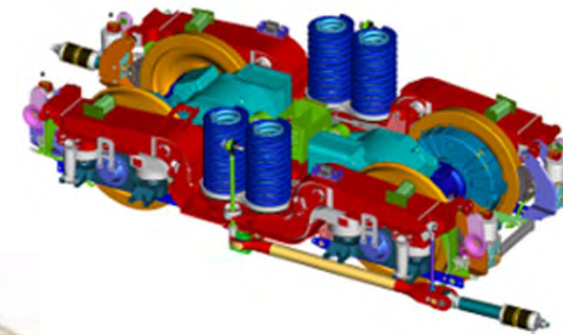

Development / Design

2005 - 2006 **CONNEXION, Netherlands**
(for Fahrzeugtechnik Dessau)

- Concept design and development of motor and trailer bogies for the PROTOS regional train units
- These multiple units are designed for service operation in several countries of Europe

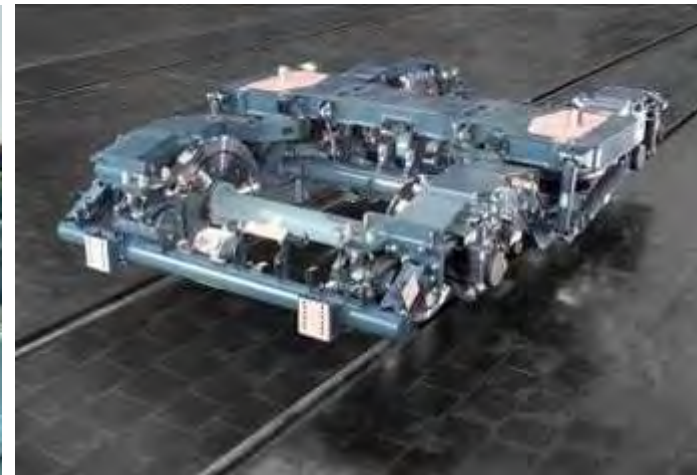

Development / Design

2003 - 2005 Finnish State Railways (VR), Finland (for Transtech)

- Concept design and development of the TB 201 bogies for Transtech for double deck sleeping and intercity coaches (production of 86 bogies at Stadler in Winterthur, Switzerland)

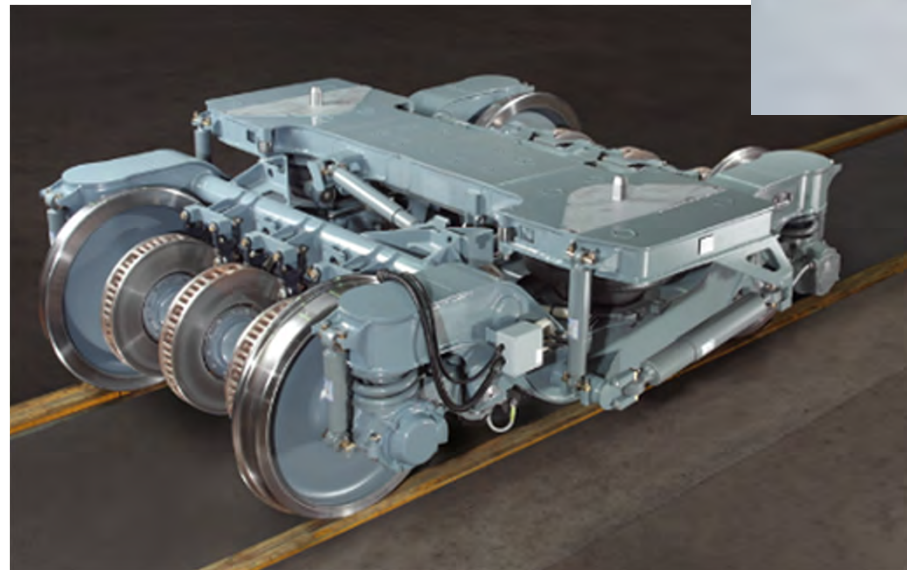

- This bogie is designed for a operational speed of 200 km/h under tough Finnish winter conditions

Development / Analysis

2000 – 2002 West Coast Main Line, Pendolino UK
Customer: Alusuisse Road & Rail

- PROSE performed strength analysis and proof of fatigue strength of the aluminum carbody



Development / Design

1996 – 1999 Transrapid Maglev

TR08: main line Germany

TR08: airport express Shanghai

TR09: airport express Munich

- Design of the mechanical part (carbody, running gears, crash elements, etc.)
- Elaboration of all relevant specifications
- System integration of all sub systems (doors, HVAC, PIS, etc.)
- Definition of the vehicle layout in cooperation with customers
- Compliance with acoustic requirements proven by flow analysis
- Fire protection concept and material selection
- Layout of components for optimised maintenance processes
- Design of interiors



Development / Design

1993 - 1998 LRT for New Jersey Transport, U.S.A.

(for SIG Swiss Industrial Company / KINKI Sharyo Japan)

- Concept design of the articulation joint and the low-floor central bogie for the low floor light rail vehicle for NJT
- Detail design of the central trailing bogie as well as structural analysis of the articulation joint and dynamic simulation (running dynamics simulation)

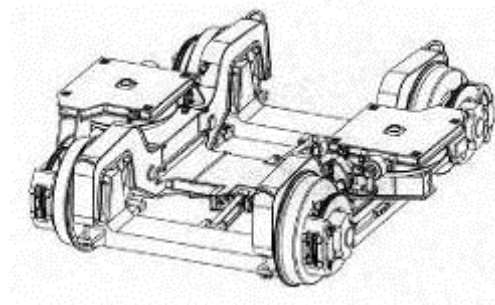

Development / Design

1987 - 1991 Coal Mine Locomotive for the „General Blumenthal“ Mine, Germany

(for SIG Swiss Industrial Company)

- Project management for the development of a high-end compound locomotive able to operate in potential explosive surroundings (catenary / battery)
- Motor bogie design

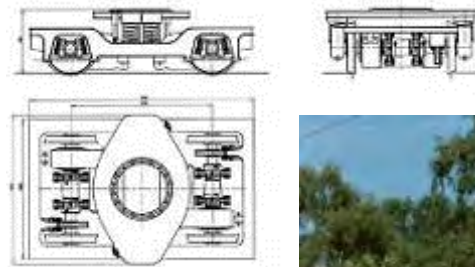

Development / Analysis

2000 - 2005 Analysis of running dynamics for several customers

- assessment of several low-floor light-rail-vehicles in the USA in regard to running dynamics and safety against derailment
- NSB Class 70 and Class 72
- ballast transport wagons
- innovative rail vehicles with individually controlled loose wheels



Development / Analysis

2000 - 2003

Several customers

(for Bombardier, Switzerland and Sweden)

- Supporting design-teams for several bogie types
- FE calculations in parallel to the design, consulting concerning the achievement of structural integrity
- Specifications for the fatigue testing of bogie frames and components

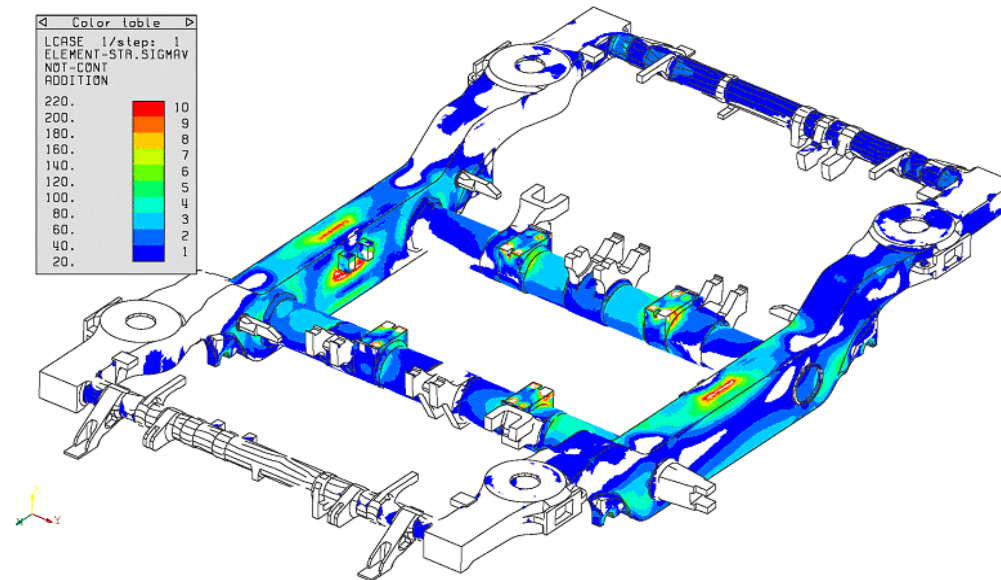

Calculation / Simulation / Crash

2010 - 2011 Transtech OY

- Development of the crash concept for a new steering car which will be ordered by VR (Finnish railway)
- Double deck intercity trains, with sleeping cars and day cars. The coaches are designed for a maximum speed of 200 km/h
- The crash analysis (calculation and simulation) according EN 15227:
 - scenario 1: collision between two identical cars with 36 km/h
 - scenario 2: steering car against a 80 t wagon with 36 km/h
 - scenario 3. steering car against a defined obstacle with 110 km/h

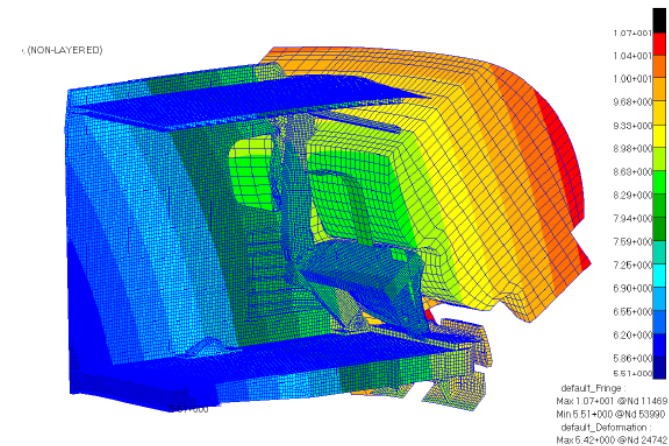

Refurbishing / Analysis

2010 - 2017 SBB LION DPZ+

- Engineering for the refurbishment of rolling stock for the Zurich S-Bahn system. Strength analysis of complete bogies, supervision of fire protection requirements, improvement of traction and brake unit of the locomotive, leading approval process for upgraded DPZ+-composition
- 115 units of three different coach types plus the locomotive will be refurbished (e.g. equipped with air conditioning)

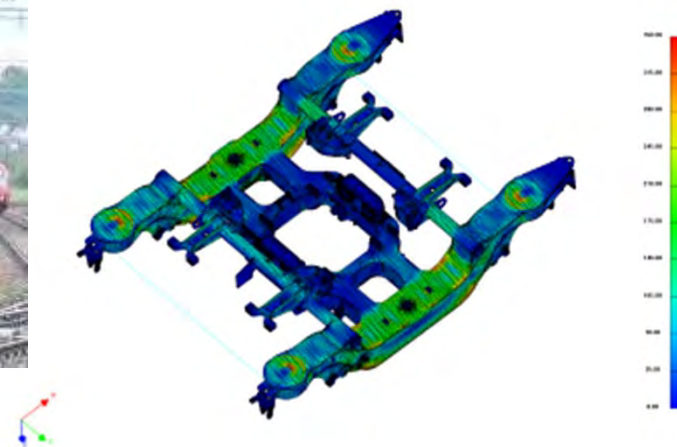

Refurbishing / Design

2007 - 2008 SBB Swiss Federal Railways

(in a consortium with ENOTRAC and Helbling)

- Mid-life refurbishment of the “New Commuter Train” NPZ; responsible for the bogies, underframe equipment and driver’s cabs (engineering, production of manufacturing drawings, structural calculations, etc.)
- PROSE performs the weight management, RAMS-LCC and the management of the homologation of the refurbished EMUs



Project Management

1994 - 1995 **SBB, Switzerland, CP, Portugal and other customers** (for FIAT SIG and Bombardier, Switzerland)

- Project management of several bogie development projects
- Project management for the development and product validation of the bogies and the electromechanical tilting system of the Swiss intercity tilting train ICN



- analogue activities also for test rig development, vehicle introduction, adaptation of workshop

Coaching

1998 - 2002 **Chung Shan Institute of Science & Technology
Taiwan**

- Elaboration of a state-of-the-art study and development of a concept for low-floor trams for different cities in Taiwan.
- Development of a conceptual design and coaching of a local design team.



Protection against Vibration

2011 – 2012 SBB Environment

- Study with recommendations for vibration mitigation measures on rolling stock within the EU-project RIVAS
 - Statistical analysis and evaluation of vibration measurements and out-of-roundness data
 - Correlation of vibration data to rolling stock parameters
 - Cost-benefit analysis of vibration mitigation measures on rolling stock

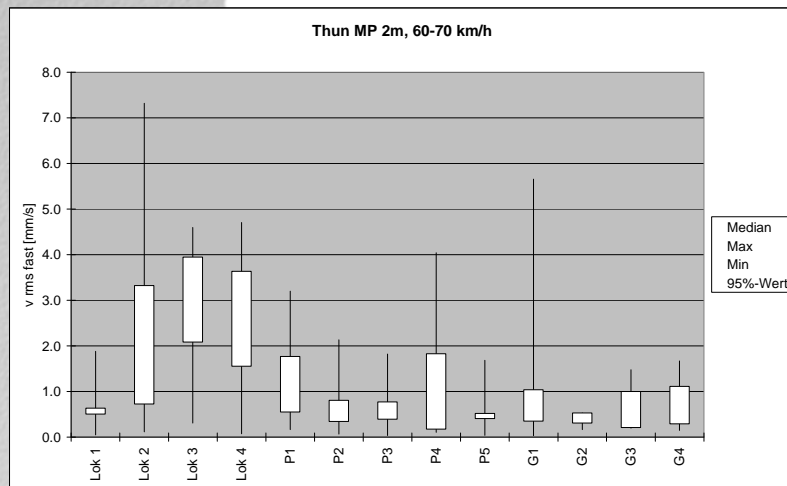

Noise abatement at rolling stock

2002 - today

various customers



- Concepts for noise reduction
 - Analysis of noise sources and noise propagation
 - Brake system: elimination of cast iron brake shoes
 - Improvements at the auxiliary inverter control
 - Noise shielding, damping and absorption, etc.
 - Preparing of test installations

Environmental Noise

2007 - today various customers

- Studies and elaboration of solutions for regions with high exposure to railway noise
 - Noise modelling and prediction
 - trackside measurements for various noise abatement solutions
 - measurement on rolling stock, proposals for different solutions

Eisacktal (Südtirol)



Rheintal (D) ©BMU 2009



Macro slip noise

2010 SBB Re 450

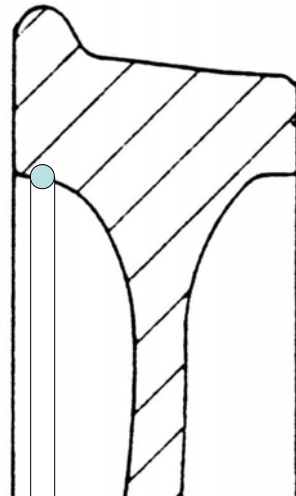

2867 Hz

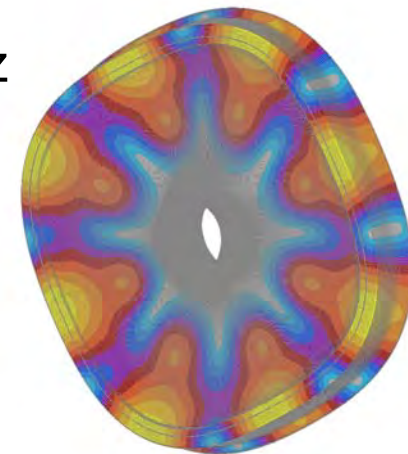

Macro slip noise on traction wheel sets

- Improvement of traction control
- Analysis of the spectral content
- FEM modelling of wheels
- Wheel absorber evaluation



Output Set Mode 16, 2867.834 Hz
 Displacement: Total Translation
 Control: Total Translation

Research

2003

Swiss Agency for the Environment, Switzerland

- PROSE was commissioned to perform detailed measurements as general contractor to define the noise targets for modified freight wagons.
- The contract included the preparation of a reference track section, modifications of the wagons, operations, measurements, analysis, report and know-how transfer



STS 409

Machine Noise Regulation

2008 - today Engineering Industry

- Notified Body according to Directive 2000/14/EC
(limitation of noise emission for outdoor equipment)



Management Support & Consulting

- Optimisation of the maintenance scheme of the Swiss “Zentralbahn“ Railway
 - Performance of 6 seminars held with workshop staff

- Procurement / evaluation of new rolling stock
 - For light rail system of KCRC in Hongkong
 - For Israel Railways all rolling stock purchases since 1991
 - For new interregional trains for the Swiss “Zentralbahn“ Railway



Homologation Process

2010 Track grinding machine GRIZZLY Coordination of homologation at German EBA (for Scheuchzer SA)

- Structural analysis, proof-calculation and expertises
- Performance of running dynamic tests, noise and brake system tests, EMC -testing
- Organisation of the complete test program
- Preparation of all the documents necessary for submission to EBA .
- EMC-Testing
- Preparation of the vehicle documentation required by the German Safety Authority (EBA)



Room Acoustics and Intelligibility

2010 Measurement of intelligibility

(on behalf of Transtech Oy, Finland)

- Measurement of intelligibility at seats in a double-deck passenger coach
- Reverberation time and level diminution in vehicle's interior
- Analysing of speak transmission index (STI)
- Analysing of privacy index (PI)
- Artificial speaker for announcements

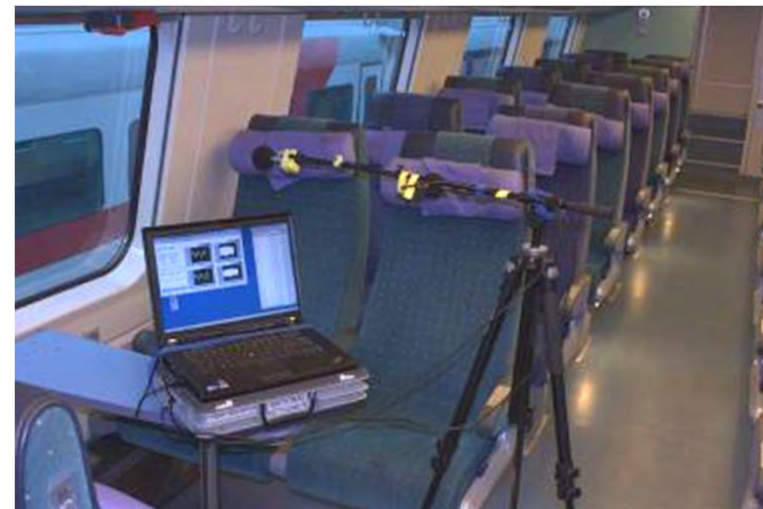

Simulation / Acoustics / Vehicle

2010 – today: Exterior noise simulation of vehicles

- Emission simulation with the sonRAIL emission tool
- Rolling noise simulation and bogie noise (SKODA 2010)
- Complete exterior noise simulation of a tramway for standstill and driving mode (Transtech Oy, 2011)

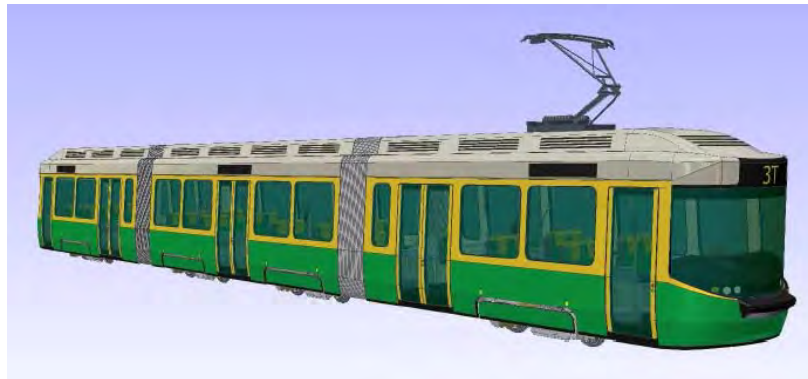

Transtec Oy MLRV01

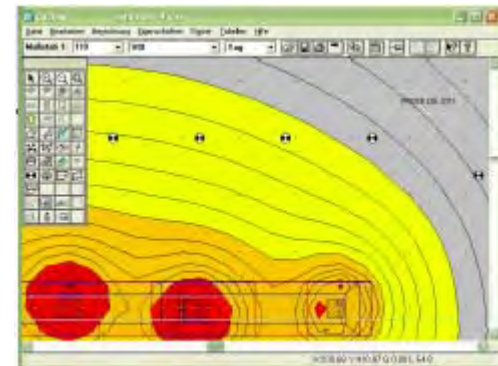

Simulation / Acoustics / Vehicle

2011: Korean Railroad Institute KRRI Speed Railways Noise Calculation Tool

- Consultancy on the procedural method of developing noise prediction tool for high speed railway
- Related sonRAIL investigations, results, measurements



Expert Opinions

2013 **Fire safety assessment** (on behalf of TÜVASAS, Turkey)

- Fire safety assessment as part of the TSI certification on a standard sleeper coach and a sleeper coach accessible to people with reduced mobility
- Assessment of material fire properties with regard to the requirements of DIN 5510-2:2009



Electrical engineering

- Systems design for the electrical fittings
- Electrical installation design
- Elaboration of specifications for electrical installations and train control and monitoring systems
- Elaboration of technical documents for the wiring and the integration of electrical components

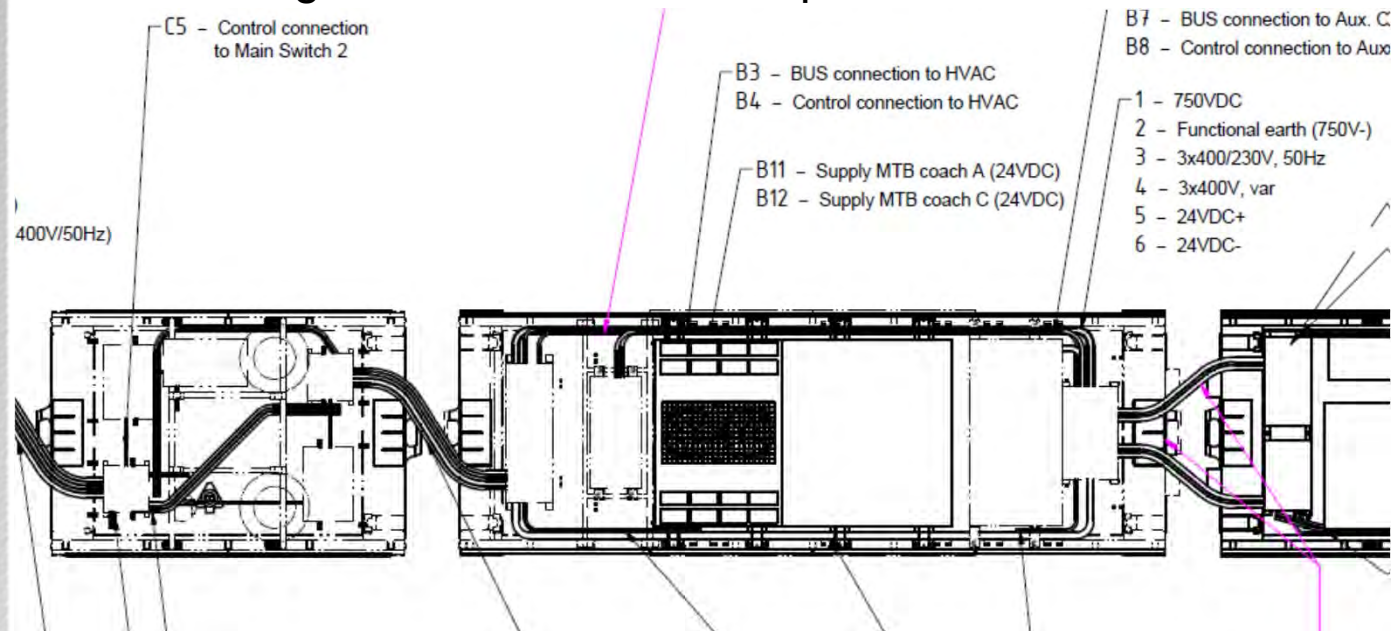

Thank you for your attention !



PROSE Ltd.
Zuercherstrasse 41
CH-8400 Winterthur
www.prose.ch